

2,100

SIDE ELEVATION

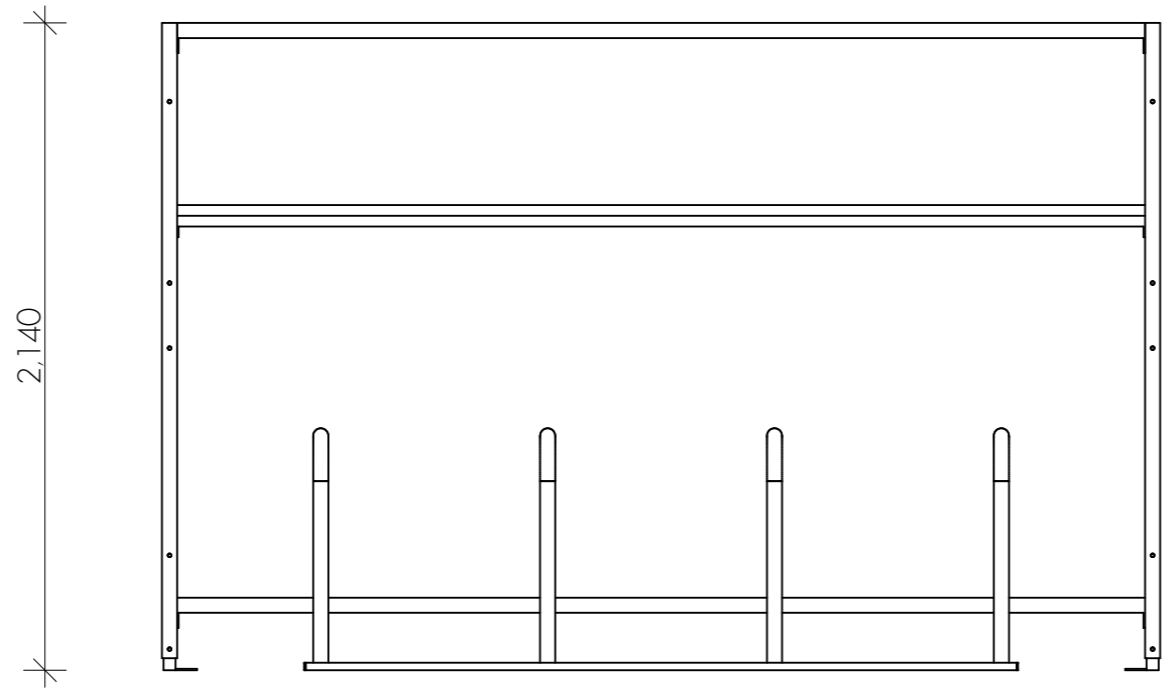

2,140

3,300

FRONT ELEVATION

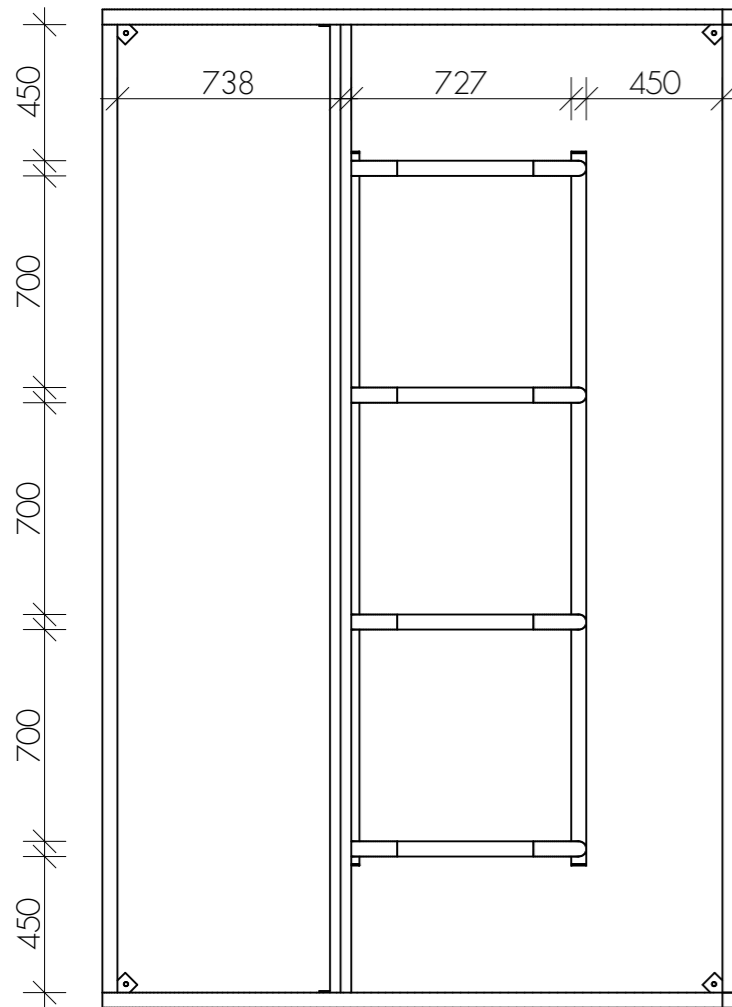

PLAN

SEE SITE LAYOUT PLANS 18205-PLA-001 FOR PROPOSED LOCATIONS AND FFL'S

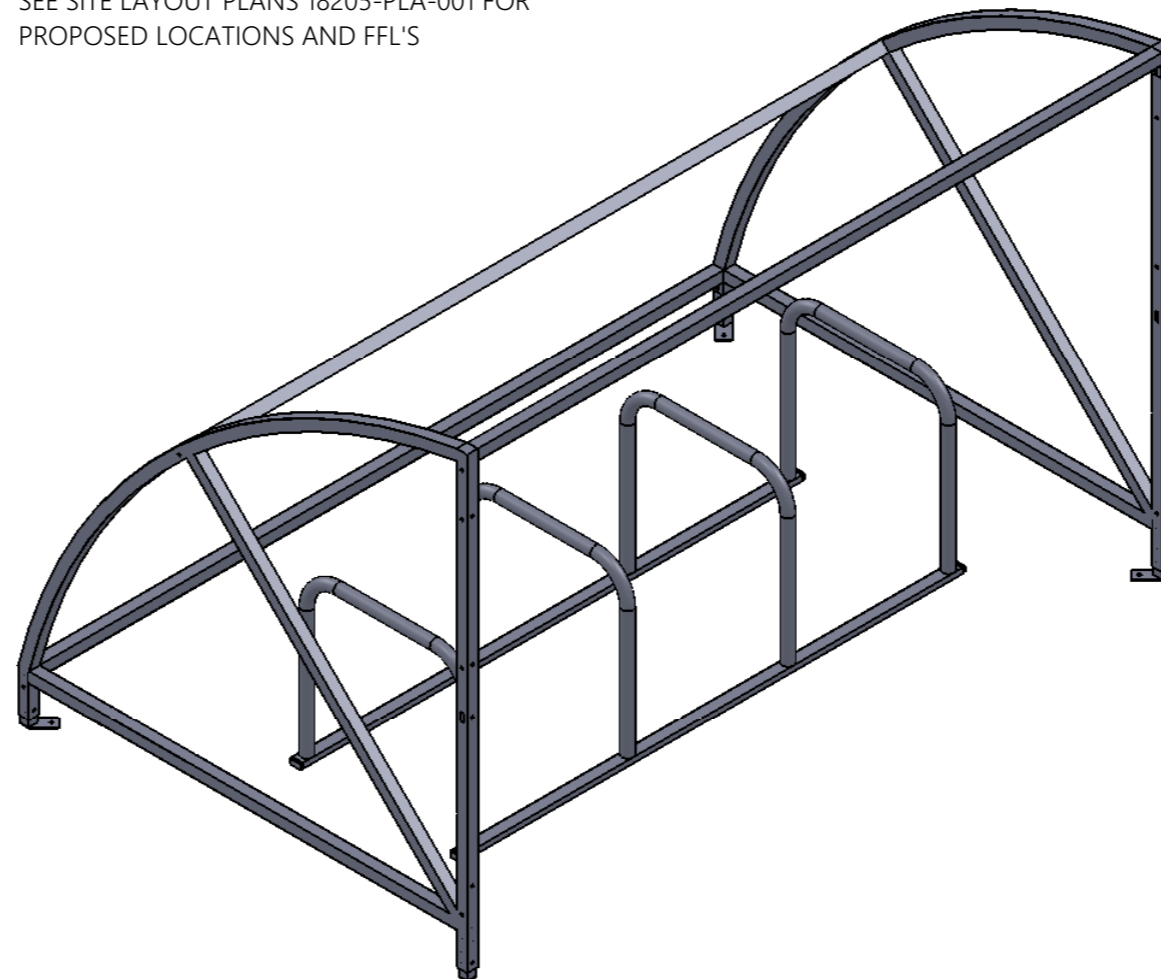

Bicycle shelter, mild steel frames bolt down to ground. Shelter to be in either a galvanised or polyester powder coated RAL code colour finish. Anti-vandal 3mm clear polycarbonate roof, galvanised bike stands



TYPICAL BIKE STAND



TYPICAL BIKE STAND

Issue Description	VB	12/04/2019	X
dm	ckd	date	rev.
Issued for Planning			
Client: CAIRN HOMES PROPERTIES LTD.			
Project: RESIDENTIAL DEVELOPMENT			
Site: CASTLETREASURE, DOUGLAS, CO. CORK			
Title: TYPICAL BIKE STAND DETAIL			



Project Architect: PATRICK O'TOOLE  
A3 Sheet Scale: 1:25 1:100 1:6667

Project No: 18205-PLA-021  
Issue: A

Meitheal  
design partners  
Architects